

2 Horse Bumper Pull Walk-Thru Classic

**Safe,
Comfortable,
Versatile
and Stylish.**

HAWK's design experience and attention to detail equals unmatched quality and value. Travel in confidence with the industry leader.



Standard Features Include:

- Fully Lined and Insulated Walls and Doors
- White or Silver Aluminum Outer Shell
- Custom Painted Accent Color
- Fiberglass Roof and Fenders
- Powder Coated Removable Interior Parts
- T-Coated Latches and Hardware
- Transferrable Warranty
- Sealed Fuse Box



Hawk
TRAILERS



TRAILERS

HAWK TRAILERS

2 H Bumper Pull Walk Thru Classic

	18'10" w/dress Custom	18'10" w/dress Elite	15'6" Custom	15'6" Elite
Overall Length	18'10"	18'10"	15'6"	15'6"
Width 80"	S	S	S	S
Stall Length 7'6"	S	S	S	S
Inside Height 7'8"	S	S	S	S
2-5/16" wedge lock coupler	S	S	S	S
Sidewind Jack w/sandfoot in coupler Elite only dolly/wheel	S	S	S	S
Axle Capacity 7000# w/4 wheel electric brakes	S	S	S	S
ST205/75R15(C) Radial Silver rims, Elite Aluminum rims	S	S	S	S
Spare Tire & rim mounted inside no cover	S	S	S	S
Front wedge w/20x24 wdws	S	S	n/a	n/a
20x24 wdws in dress door	S	S	O	S
20x24 wdws in walk thru door	S	S	O	S
20x24 wdws at horses head area	S	S	O	S
Storm doors & stainless steel cam latches	S	S	O	S
Sidewall wdws 20x51 (1) each side	S	S	S	S
Carpet on floor in dress	S	S	n/a	n/a
Carpet on bulkhead wall	O	S	n/a	n/a
Saddle racks	2	2	n/a	n/a
Bridle hook set bolt on (6) aluminum	S	S	O	O
Door tie backs on all doors	S	S	O	S
Aluminum running boards	S	S	O	S
Diamond plate on steps, & tongue	S	S	S	S
Diamond plate on fenders half, full length Elite only	S	S	S	S
Diamond plate on nose, 18" high	S	S	S	S
Rubberline sidewalls	S	S	S	S
Breast/butt bar pads	O	S	O	S
Divider & sidewall pads	1"	2"	1"	2"
Rear header pad	S	S	S	S
Floor mats 5/8"	S	S	S	S
Roof vents	2	2	2	2
Brush tray on dress door	S	S	n/a	n/a
Square feed bag (1) per stall	S	S	S	S
Interior head ties (3) per stall	S	S	S	S
Exterior head ties (1) per horse	S	S	S	S
Fuse block	S	S	S	S
Dome lights	2	3	1	2
Remote switch horse area lights	O	S	O	S
D.O.T Lighting	S	S	S	S
Empty trailer weight	3700 lbs	3700 lbs	3200 lbs	3200 lbs
Limited warranty on all products. See dealer for details.	7Yr	7Yr	7Yr	7Yr

HAWK TRAILERS RESERVES THE RIGHT TO CHANGE SPECIFICATIONS AND PRICES WITHOUT NOTICE.

EFFECTIVE 5/8/16

2 Horse Bumper Pull Walk-Thru With Dress

2 Horse Bumper Pull Walk-Thru

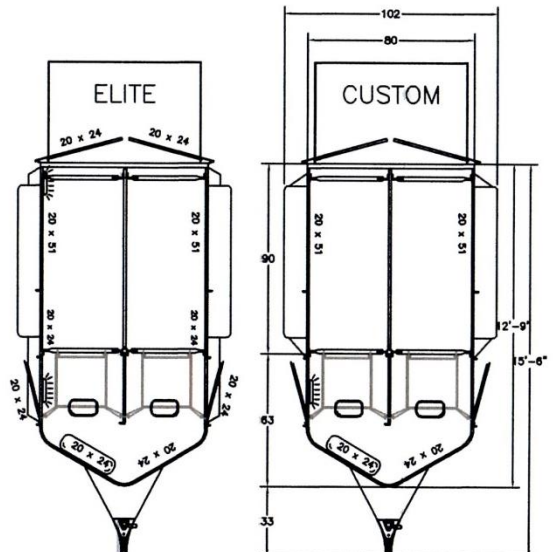
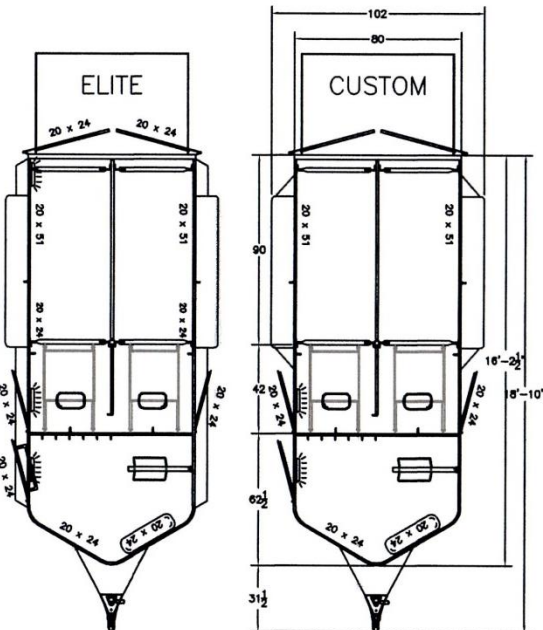

HAWK TRAILERS

2 H Bumper Pull Walk Thru Classic

	w/dress Custom	w/dress Elite	Custom	Elite
	18'10"	18'10"	15'6"	15'6"
Overall Length	S	S	S	S
Width 80"	S	S	S	S
Stall Length 7'6"	S	S	S	S
Inside Height 7'8"	S	S	S	S
2-5/16" wedge lock coupler	S	S	S	S
Sidewind Jack w/sandfoot in coupler Elite only dollywheel	S	S	S	S
Axle Capacity 7000# w/4 wheel electric brakes	S	S	S	S
ST20575R15(C) Radial Silver rims, Elite Aluminum rims	S	S	S	S
Spare Tire & rim mounted inside no cover	S	S	S	S
Front wedge w/20x24 wdws	S	S	S	S
20x24 wdw in dress door	O	S	n/a	n/a
20x24 wdw in walk thru door	S	S	O	S
20x24 wdws at horses head area	O	S	O	S
Storm doors & stainless steel cam latches	S	S	S	S
Storm door windows 20x24	O	S	O	S
Sidewall wdw 20x51 (1) each side	S	S	S	S
Carpet on floor in dress	S	S	n/a	n/a
Carpet on bulkhead wall	O	S	n/a	n/a
Saddle racks	2	2	n/a	n/a
Bridle hook set bolt on (6) aluminum	S	S	O	O
Door tie backs on all doors	S	S	S	S
Aluminum running boards	O	S	O	S
Diamond plate on steps, & tongue	S	S	S	S
Diamond plate on fenders half, full length Elite only	S	S	S	S
Diamond plate on nose, 18" high	O	S	O	S
Rubberline sidewalls	S	S	S	S
Breast/butt bar pads	O	S	O	S
Divider & sidewall pads	1"	2"	1"	2"
Rear header pad	S	S	S	S
Floor mats 5/8"	S	S	S	S
Roof vents	2	2	2	2
Brush tray on dress door	S	S	n/a	n/a
Square feed bag (1) per stall	S	S	S	S
Interior head ties (3) per stall	S	S	S	S
Exterior head ties (1) per horse	S	S	S	S
Fuse block	S	S	S	S
Dome lights	2	3	1	2
Remote switch horse area lights	O	S	O	S
D.O.T Lighting	S	S	S	S
Empty trailer weight	3700 lbs		3200 lbs	
Limited warranty on all products. See dealer for details.	7yr	7yr	7yr	7yr

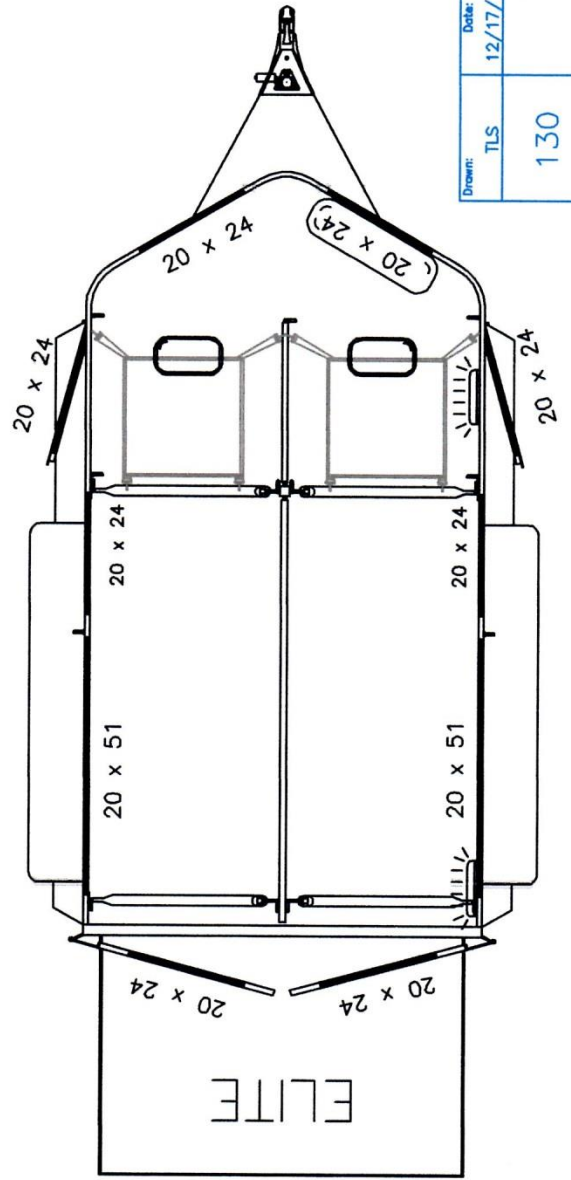
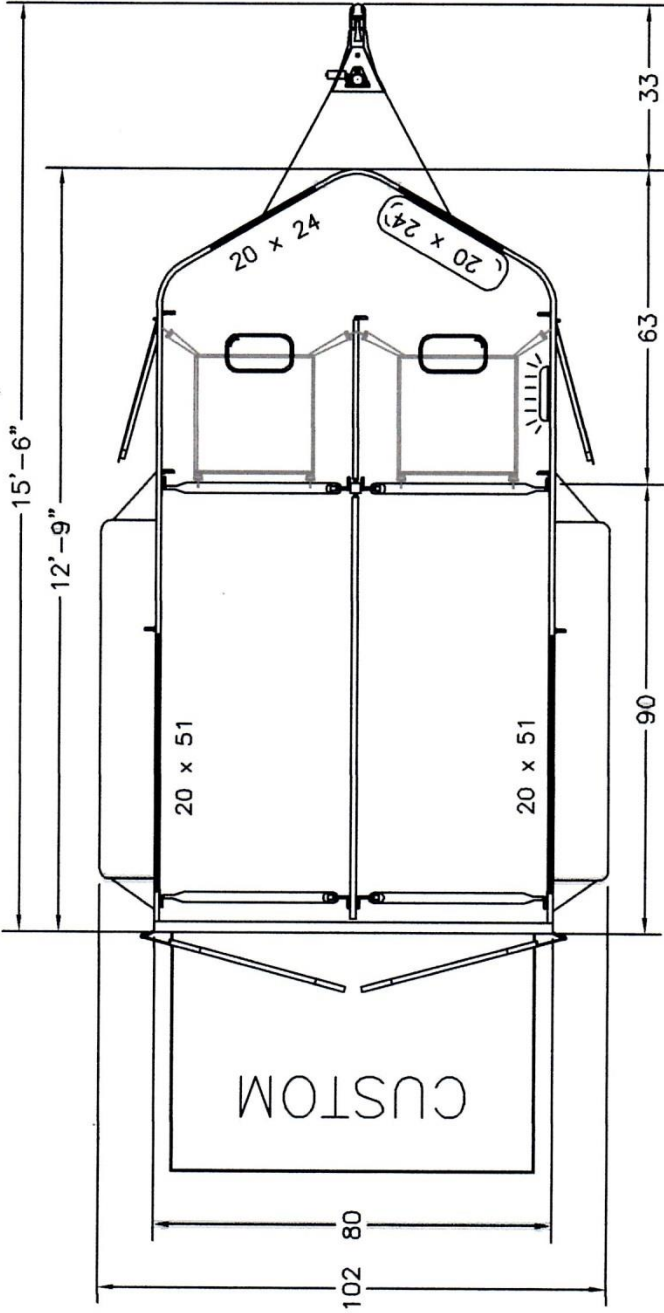

Drawn: TLS	Date: 12/17/1997	Scale: 1:34	Tolerance: $\pm \frac{1}{16}$	Rev. 12/21/07
130	2 Horse Bumper Pull Walk-Thru Classic			
 Hawk Trailers MANAWA, WI				

2 Horse Bumper Pull Walk-Thru Classic

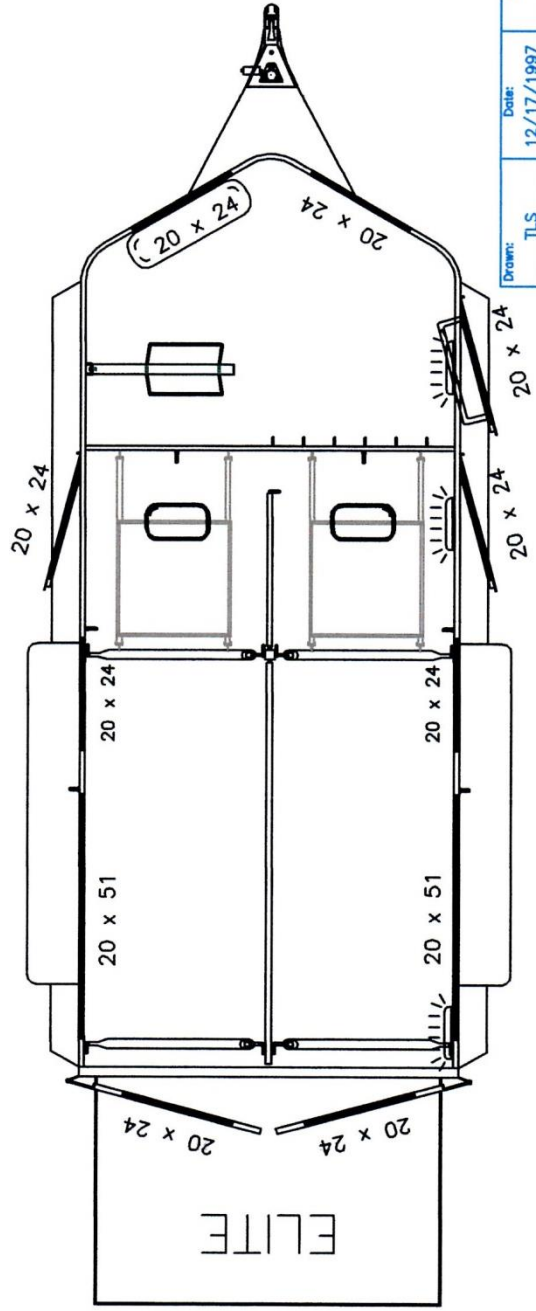
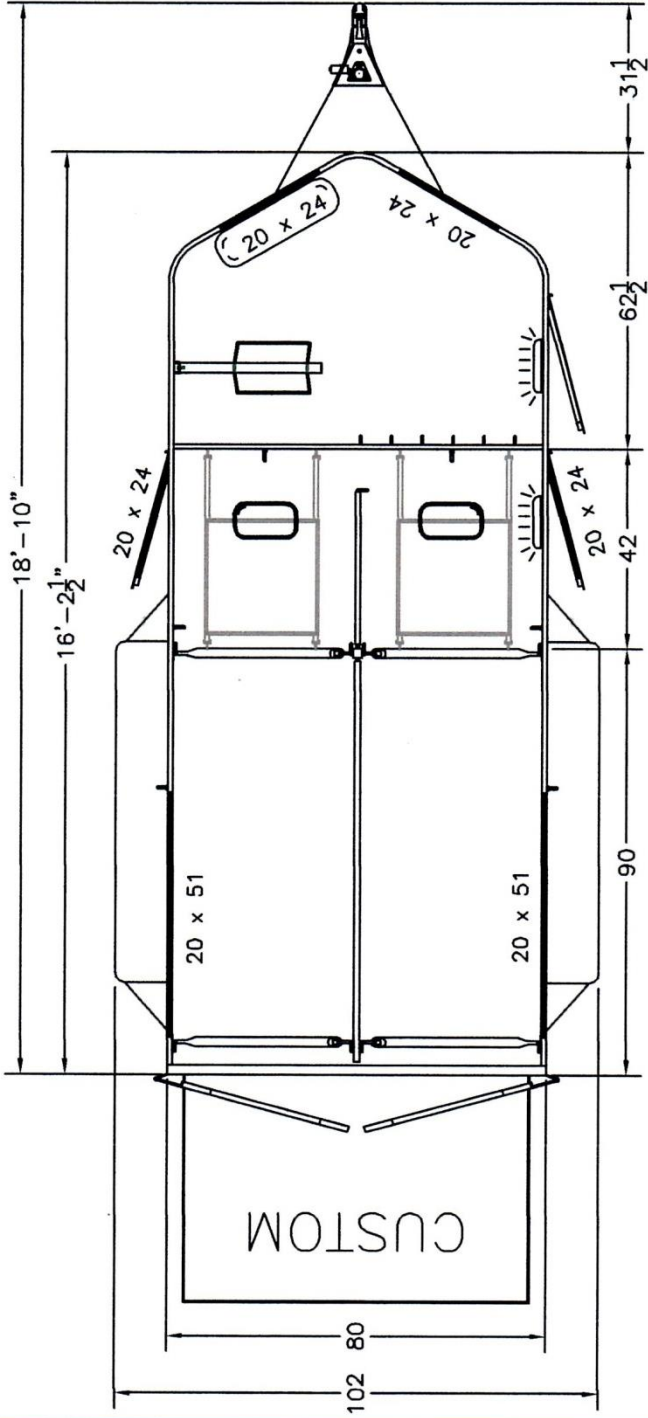

Drawn: TLS	Date: 12/17/1997	Scale: 1:36	Tolerance: $\pm \frac{1}{16}$	Rev. 12/21/07
2 Horse Bumper Pull Walk-Thru With Dress Classic				
132				
<i>Hawley Trailers</i> MANAWA, WI				

2 Horse Bumper Pull Walk-Thru With Dress Classic